

POZZETTO DI SFIATO – ACQUEDOTTO IN PEAD

DISPOSIZIONE SOTTO STRADA

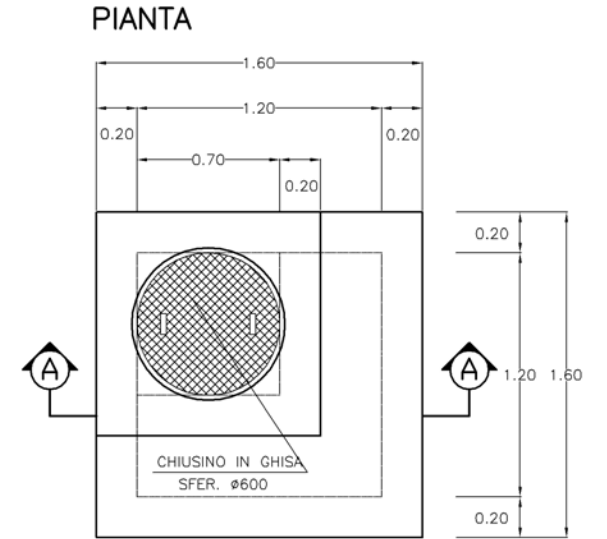

DISPOSIZIONE SOTTO MARCIAPIEDE

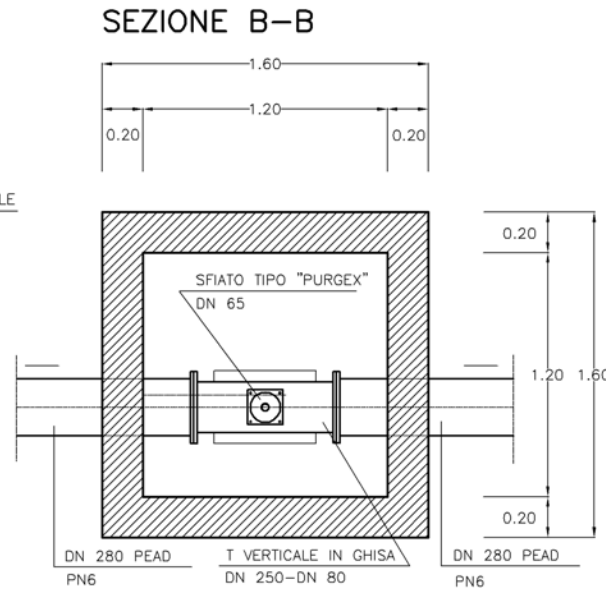
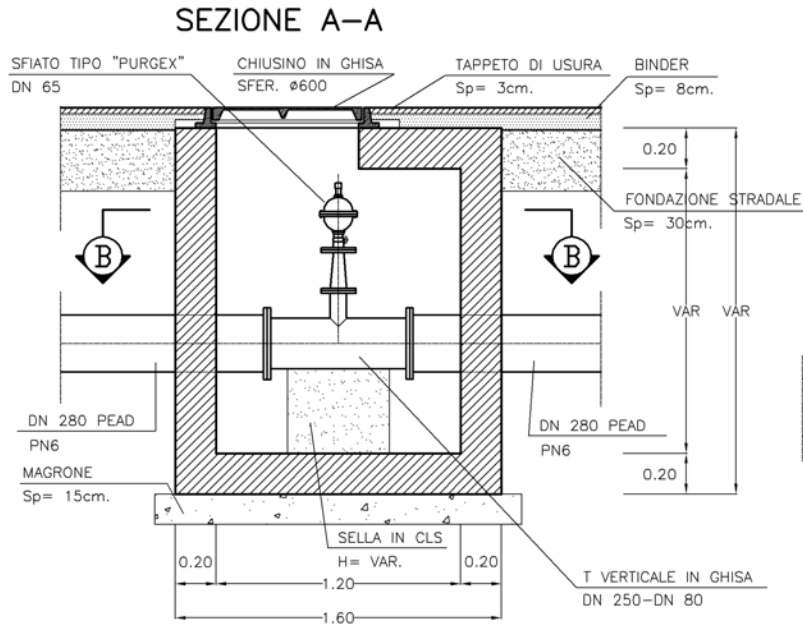